

10G SFP+ LRM Optical Transceiver

PN: OP3902D

Product Specification

Features:

- ✧ Supports 1.0 to 11.3Gb/s bit rates
- ✧ Hot-Pluggable SFP+ form factor
- ✧ Duplex LC connector
- ✧ 1310nm FP transmitter, PIN photo-detector
- ✧ MMF links up to 220m
- ✧ Built-in digital diagnostic functions
- ✧ Power Supply : +3.3V
- ✧ Power consumption<1W

✧ Operating case temperature: 0~ 70°C

✧ RoHS compliant

Applications:

- ✧ 10G Ethernet
- ✧ SDH/SONET
- ✧ Fibre Channel

Description:

The OP3902D is a very compact 10Gb/s optical transceiver module for serial optical communication applications at 10Gb/s. The OP3902D converts a 10Gb/s serial electrical data stream to 10Gb/s optical output signal and a 10Gb/s optical input signal to 10Gb/s serial electrical data streams. The high speed 10Gb/s electrical interface is fully compliant with SFI specification.

The high performance 1310nm FP transmitter and high sensitivity PIN receiver provide superior performance for Multiple applications up to 220m links on MMF.

The SFP+ Module compliants with SFF-8431, SFF-8432. Digital diagnostics functions are available via a 2-wire serial interface, as specified in SFF-8472.

The fully SFP compliant form factor provides hot pluggability, easy optical port upgrades and low EMI emission.

● Absolute Maximum Ratings

Parameter	Symbol	Min.	Typical	Max.	Unit
Storage Temperature	T _S	-40		+85	°C
Case Operating Temperature	T _A	0		70	°C
Maximum Supply Voltage	V _{CC}	-0.5		4	V
Relative Humidity	RH	0		85	%

● Electrical Characteristics

Parameter	Symbol	Min.	Typical	Max.	Unit	Note
Supply Voltage	V _{CC}	3.135		3.465	V	
Supply Current	I _{CC}			300	mA	
Power Consumption	P			1	W	
Transmitter Section:						
Input differential impedance	R _{in}		100		Ω	1
Differential input voltage swing	V _{in,pp}	100		1000	mV	
Transmit Disable Voltage	V _D	2		V _{CC}	V	
Transmit Enable Voltage	V _{EN}	V _{EE}		V _{EE} +0.8	V	
Receiver Section:						
Differential output voltage swing	V _O	300		1000	mV	
LOS Fault	V _{LOS fault}	2		V _{CCHOST}	V	2
LOS Normal	V _{LOS norm}	V _{EE}		V _{EE} +0.8	V	2

Note:

1. Connected directly to TX data input pins. AC coupling from pins into laser driver IC.
2. LOS is an open collector output. Should be pulled up with 4.7k – 10kΩ on the host board. Normal operation is logic 0; loss of signal is logic 1.

● Optical Parameters

Parameter	Symbol	Min.	Typical	Max.	Unit	Note
Transmitter Section:						
Center Wavelength	λ _t	1260	1310	1355	nm	
RMS spectral width	λ _{RMS}			4	nm	
Average Optical Power	P _{avg}	-6.5		-1	dBm	
Laser Off Power	P _{off}			-30	dBm	
Extinction Ratio	ER	3.5			dB	
Receiver Section:						
Center Wavelength	λ _r	1260	1310	1620	nm	
Receiver Sensitivity	Sen			-11.1	dBm	1
Input Saturation Power(Overload)	Sat	0			dBm	
Los Assert	LOS _A	-30		-	dBm	
Los De-assert	LOS _D			-12	dBm	
Los Hysteresis	LOS _H	0.5			dB	

Note

1. Measured with a PRBS 2³¹-1 test pattern, @10.3125Gb/s, BER < 10⁻¹².

● **Pin Assignment**

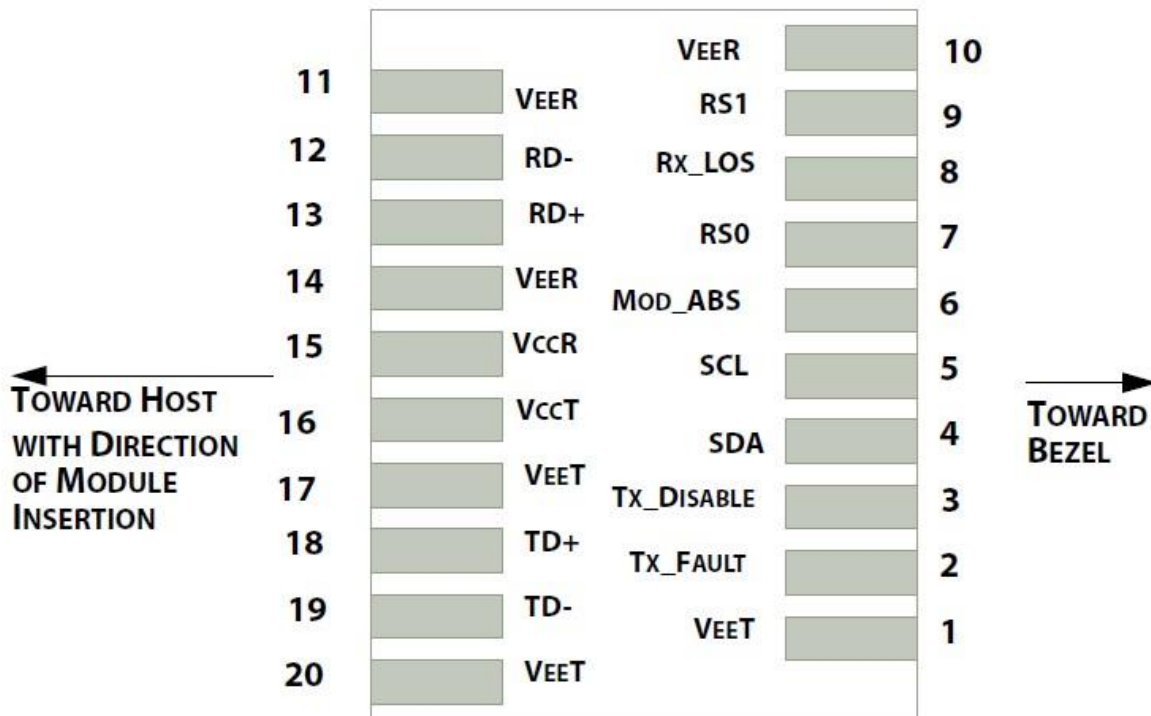

Diagram of Host Board Connector Block Pin Numbers and Names

● **Pin Function Definitions**

PIN #	Name	Function	Notes
1	VeeT	Module transmitter ground	1
2	Tx Fault	Module transmitter fault	2
3	Tx Disable	Transmitter Disable; Turns off transmitter laser output	3
4	SDA	2 wire serial interface data input/output (SDA)	
5	SCL	2 wire serial interface clock input (SCL)	
6	MOD-ABS	Module Absent, connect to VeeR or VeeT in the module	2
7	RS0	Rate Select 0. Not Used	
8	LOS	Receiver Loss of Signal Indication	4
9	RS1	Rate Select 1. Not Used	
10	VeeR	Module receiver ground	1
11	VeeR	Module receiver ground	1
12	RD-	Receiver inverted data out put	
13	RD+	Receiver non-inverted data out put	
14	VeeR	Module receiver ground	1
15	VccR	Module receiver 3.3V supply	
16	VccT	Module transmitter 3.3V supply	
17	VeeT	Module transmitter ground	1

18	TD+	Transmitter non-inverted data out put	
19	TD-	Transmitter inverted data out put	
20	VeeT	Module transmitter ground	1

Notes:

- 1.The module ground pins shall be isolated from the module case.
- 2.This pin is an open collector/drain output pin and shall be pulled up with 4.7K-10Kohms to Host_Vcc on the host board.
- 3.This pin shall be pulled up with 4.7K-10Kohms to VccT in the module.
- 4.This pin is an open collector/drain output pin and shall be pulled up with 4.7K-10Kohms to Host_Vcc on the host board.

● SFP Module EEPROM Information and Management

The SFP modules implement the 2-wire serial communication protocol as defined in the SFF -8472. The serial ID information of the SFP modules and Digital Diagnostic Monitor parameters can be accessed through the I²C interface at address A0h and A2h.

The memory is mapped in Table 1.

For more details of the memory map and byte definitions, please refer to the SFF-8472, “Digital Diagnostic Monitoring Interface for Optical Transceivers”. The DDM parameters have been internally calibrated.

Table 1. Digital Diagnostic Memory Map (Specific Data Field Descriptions)

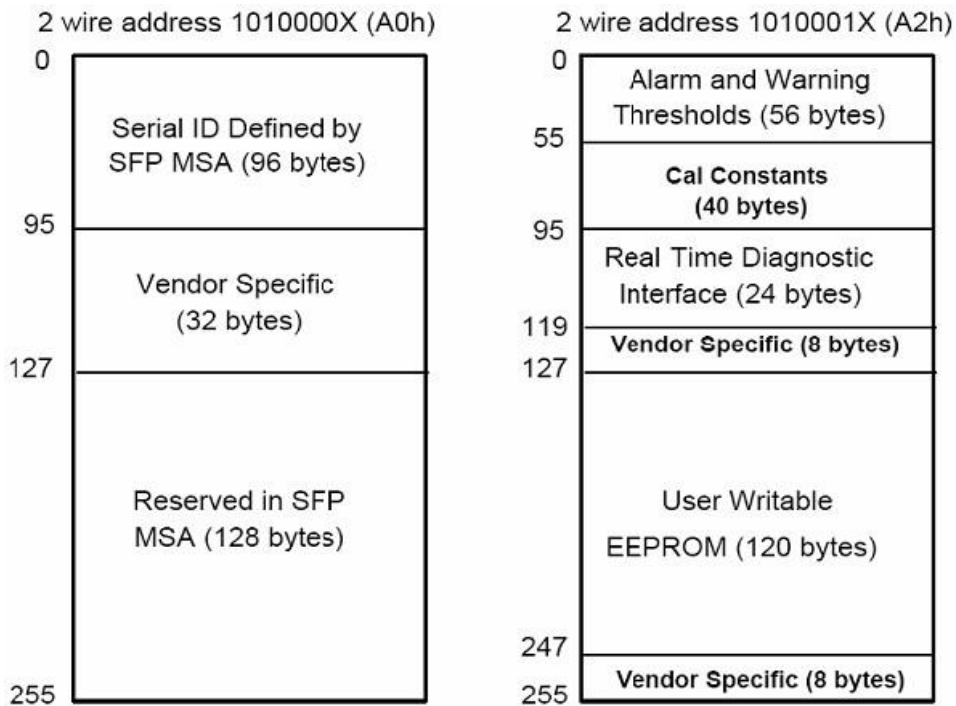

● **Digital Diagnostic Monitor Characteristics**

Data Address	Parameter	Accuracy	Unit
96-97	Transceiver Internal Temperature	±3.0	°C
98-99	VCC3 Internal Supply Voltage	±3.0	%
100-101	Laser Bias Current	±10	%
102-103	Tx Output Power	±3.0	dB
104-105	Rx Input Power	±3.0	dB

● **Recommended Circuit**

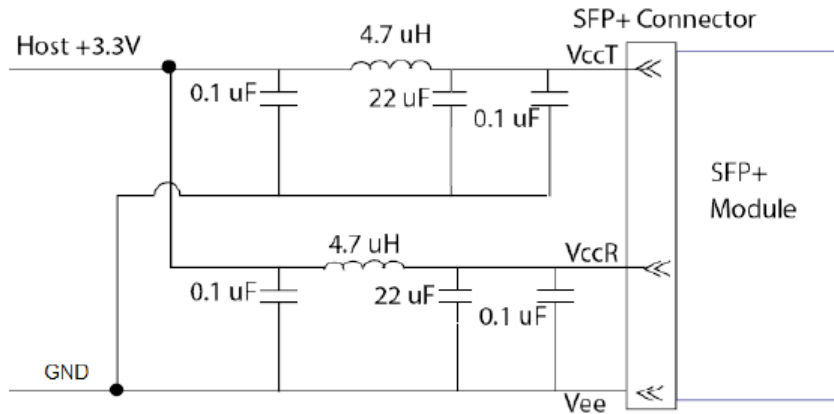

Recommended Host Board Power Supply Circuit

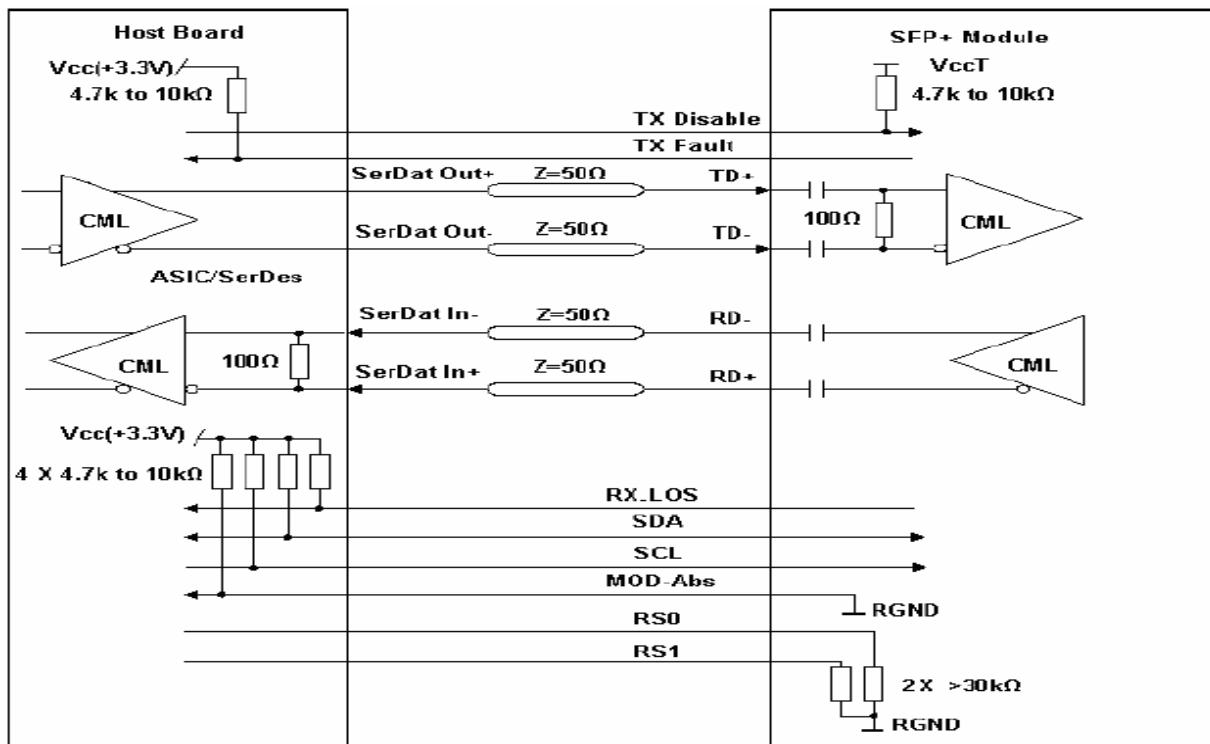

Recommended High-speed Interface Circuit

● **Mechanical Dimensions(Unit:mm)**

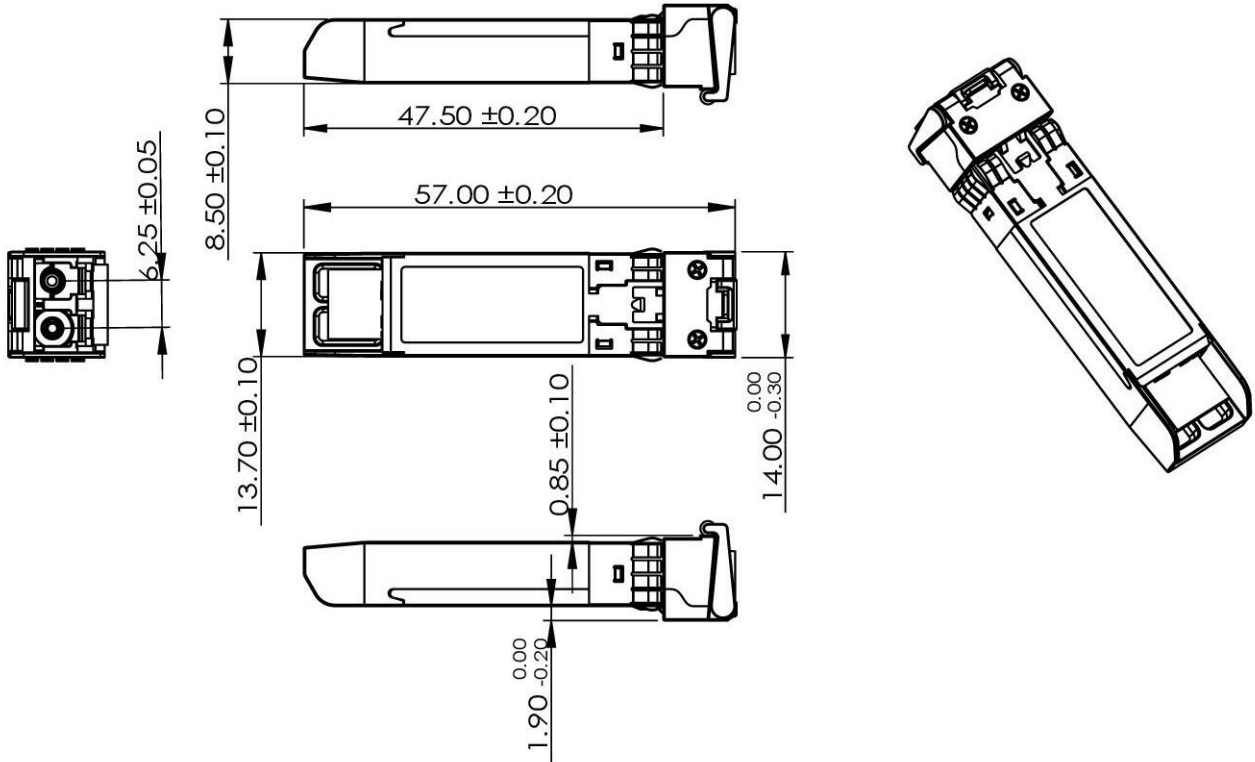

● **Document Revision**

Version No.	Date	Reviser	Description
V1.0	2023-11-06	Kevin	Template update

OPWAY reserves the right to make changes to the products or information contained herein without notice. No liability is assumed as a result of their use or application. No rights under any patent accompany the sale of any such products or information.

Published by OPWAY Communication Inc.

Copyright © OPWAY

All Rights Reserved