

10G SFP+ ZR+ Optical Transceiver

PN: OP390AD

Product Specification

Features:

- ✧ Supports 1.0 to 11.3Gb/s bit rates
- ✧ Hot-Pluggable SFP+ form factor
- ✧ Duplex LC connector
- ✧ 1550nm cooled EML transmitter, APD photo-detector
- ✧ SMF links up to 100km
- ✧ Built-in digital diagnostic functions
- ✧ Single +3.3V Power Supply
- ✧ Power consumption<1.7W

- ✧ Operating case temperature: 0~ 70°C
- ✧ RoHS compliant

Applications:

- ✧ 10G Ethernet
- ✧ SDH/SONET
- ✧ Fibre Channel

Description:

Opway's OP390AD is a very compact 10Gb/s optical transceiver module for serial optical communication applications at 10Gb/s. The OP390AD converts a 10Gb/s serial electrical data stream to 10Gb/s optical output signal and a 10Gb/s optical input signal to 10Gb/s serial electrical data streams. The high speed 10Gb/s electrical interface is fully compliant with SFI specification.

The high performance 1550nm cooled EML transmitter and high sensitivity APD receiver provide superior performance for Multiple applications up to 100km links.

The SFP+ Module compliant with SFF-8431, SFF-8432 . Digital diagnostics functions are available via a 2-wire serial interface, as specified in SFF-8472.

The fully SFP compliant form factor provides hot pluggable, easy optical port upgrades and low EMI emission.

● Absolute Maximum Ratings

| Parameter | Symbol | Min. | Typical | Max. | Unit |
|----------------------------|-----------------|------|---------|------|------|
| Storage Temperature | T _S | -40 | | +85 | °C |
| Case Operating Temperature | T _A | 0 | | 70 | °C |
| Maximum Supply Voltage | V _{CC} | -0.5 | | 4 | V |
| Relative Humidity | RH | 0 | | 85 | % |

● Electrical Characteristics

| Parameter | Symbol | Min | Typ | Max | Unit | Note |
|-----------------------------------|------------------------|-----------------|-----|----------------------|------|------|
| Supply Voltage | V _{CC} | 3.135 | | 3.465 | V | |
| Supply Current | I _{CC} | | | 515 | mA | |
| Module total power | P | | | 1.7 | W | |
| Transmitter | | | | | | |
| Input differential impedance | R _{in} | | 100 | | Ω | 1 |
| Differential input voltage swing | V _{in,pp} | 100 | | 1000 | mV | |
| Transmit Disable Voltage | V _D | 2.0 | | V _{CC} | V | |
| Transmit Enable Voltage | V _{EN} | V _{EE} | | V _{EE} +0.8 | V | |
| Receiver | | | | | | |
| Differential output voltage swing | V _O | 300 | | 1000 | mV | |
| LOS Fault | V _{LOS fault} | 2 | | V _{CCHOST} | V | 2 |
| LOS Normal | V _{LOS norm} | V _{EE} | | V _{EE} +0.8 | V | 2 |

Note:

1. Connected directly to TX data input pins. AC coupling from pins into laser driver IC.
2. LOS is an open collector output. Should be pulled up with 4.7k – 10kΩ on the host board. Normal operation is logic 0; loss of signal is logic 1.

● Optical Characteristics

| Parameter | Symbol | Min. | Typical | Max. | Unit | Note |
|----------------------------------|------------------|------|---------|------|------|------|
| Transmitter Section: | | | | | | |
| Center Wavelength | λ _t | 1530 | 1550 | 1565 | nm | |
| Spectral width | Δλ | | | 0.4 | nm | |
| Side Mode Suppression Ratio | SMSR | 30 | | | dB | |
| Average Optical Power | P _{avg} | +1.0 | | +5.0 | dBm | |
| Laser Off Power | P _{off} | | | -30 | dBm | |
| Extinction Ratio | ER | 8.2 | | | dB | |
| Transmitter Dispersion Penalty | TDP | | | 4.0 | dB | |
| Receiver Section: | | | | | | |
| Center Wavelength | λ _r | 1260 | | 1620 | nm | |
| Receiver Sensitivity | Sen | | | -24 | dBm | 1 |
| Input Saturation Power(Overload) | P _{sat} | -7 | | | dBm | |
| Los Assert | LOS _A | -35 | | - | dBm | |

| | | | | | | |
|----------------|------------------|-----|--|-----|-----|--|
| Los De-Assert | LOS _D | | | -25 | dBm | |
| Los Hysteresis | LOS _H | 0.5 | | | dB | |

Notes:

1. Measured with a PRBS 2³¹-1 test pattern, @10.3125Gb/s, BER<10⁻¹²,back to back.

● **Pin Assignment**

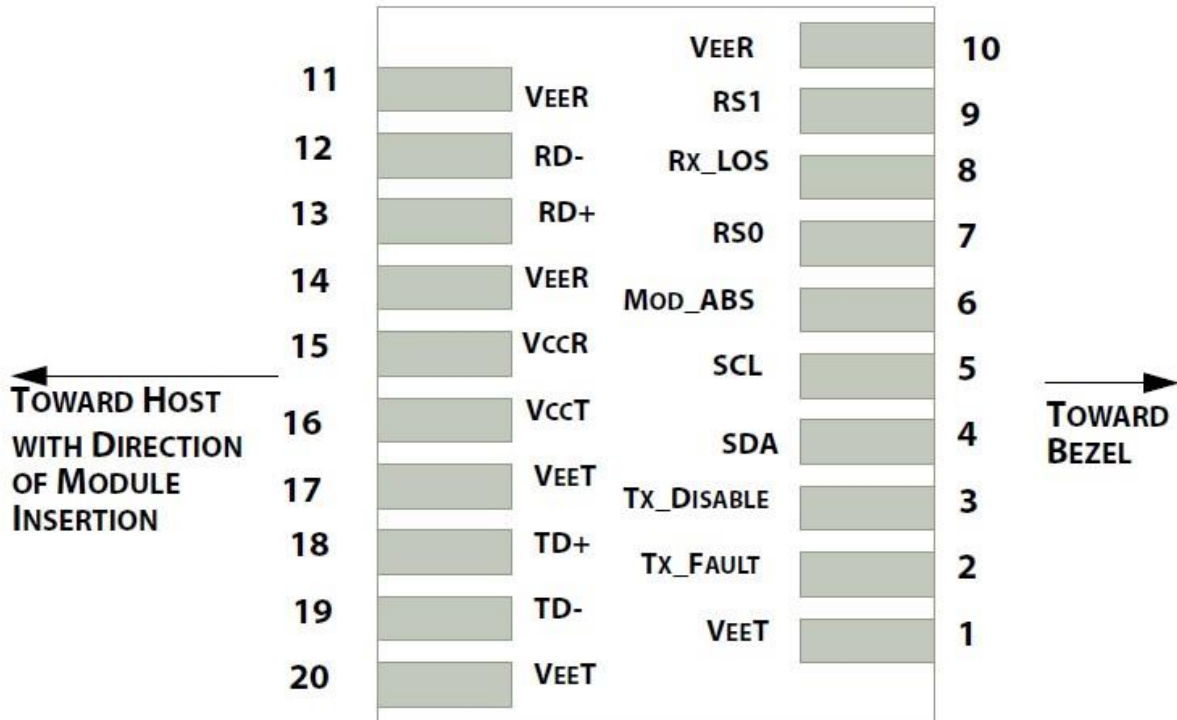

Diagram of Host Board Connector Block Pin Numbers and Names

● **Pin Function Definitions**

| PIN # | Name | Function | Notes |
|-------|------------|---|-------|
| 1 | VeeT | Module transmitter ground | 1 |
| 2 | Tx Fault | Module transmitter fault | 2 |
| 3 | Tx Disable | Transmitter Disable; Turns off transmitter laser output | 3 |
| 4 | SDA | 2 wire serial interface data input/output (SDA) | |
| 5 | SCL | 2 wire serial interface clock input (SCL) | |
| 6 | MOD-ABS | Module Absent, connect to VeeR or VeeT in the module | 2 |
| 7 | RS0 | Rate Select 0. Not Used | |
| 8 | LOS | Receiver Loss of Signal Indication | 4 |
| 9 | RS1 | Rate Select 1. Not Used | |
| 10 | VeeR | Module receiver ground | 1 |
| 11 | VeeR | Module receiver ground | 1 |
| 12 | RD- | Receiver inverted data out put | |
| 13 | RD+ | Receiver non-inverted data out put | |
| 14 | VeeR | Module receiver ground | 1 |
| 15 | VccR | Module receiver 3.3V supply | |

| | | | |
|----|------|---------------------------------------|---|
| 16 | VccT | Module transmitter 3.3V supply | |
| 17 | VeeT | Module transmitter ground | 1 |
| 18 | TD+ | Transmitter non-inverted data out put | |
| 19 | TD- | Transmitter inverted data out put | |
| 20 | VeeT | Module transmitter ground | 1 |

Notes:

- 1.The module ground pins shall be isolated from the module case.
- 2.This pin is an open collector/drain output pin and shall be pulled up with 4.7K-10Kohms to Host_Vcc on the host board.
- 3.This pin shall be pulled up with 4.7K-10Kohms to VccT in the module.
- 4.This pin is an open collector/drain output pin and shall be pulled up with 4.7K-10Kohms to Host_Vcc on the host board.

● **SFP Module EEPROM Information and Management**

The SFP modules implement the 2-wire serial communication protocol as defined in the SFF -8472. The serial ID information of the SFP modules and Digital Diagnostic Monitor parameters can be accessed through the I²C interface at address A0h and A2h.

The memory is mapped in Table 1.

For more details of the memory map and byte definitions, please refer to the SFF-8472, “Digital Diagnostic Monitoring Interface for Optical Transceivers”. The DDM parameters have been internally calibrated.

Table 1. Digital Diagnostic Memory Map (Specific Data Field Descriptions)

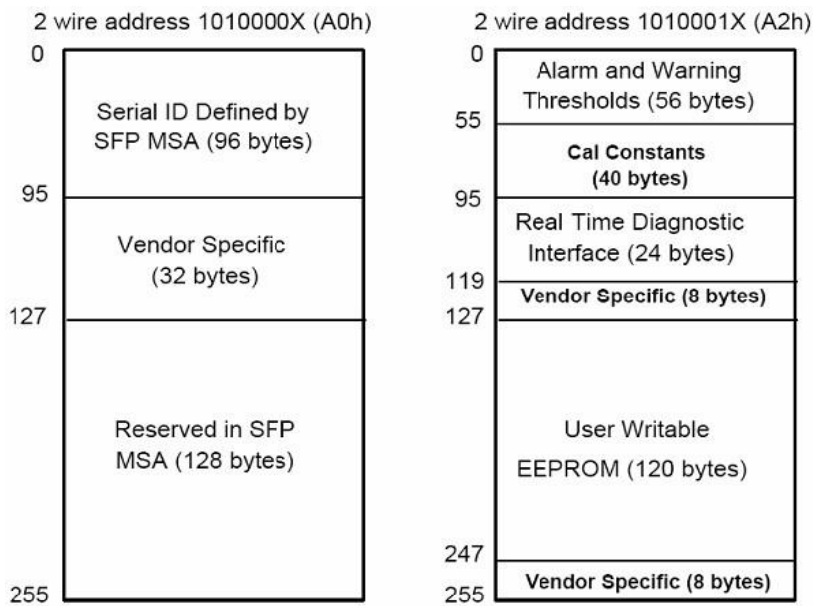

● **Digital Diagnostic Monitor Characteristics**

| Data Address | Parameter | Accuracy | Unit |
|--------------|----------------------------------|----------|------|
| 96-97 | Transceiver Internal Temperature | ±3.0 | °C |
| 98-99 | VCC3 Internal Supply Voltage | ±3.0 | % |
| 100-101 | Laser Bias Current | ±10 | % |
| 102-103 | Tx Output Power | ±3.0 | dB |
| 104-105 | Rx Input Power | ±3.0 | dB |

● **Recommended Circuit**

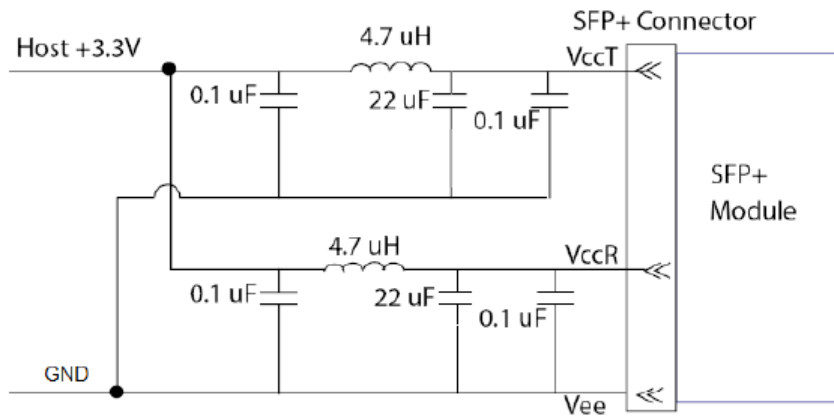

Recommended Host Board Power Supply Circuit

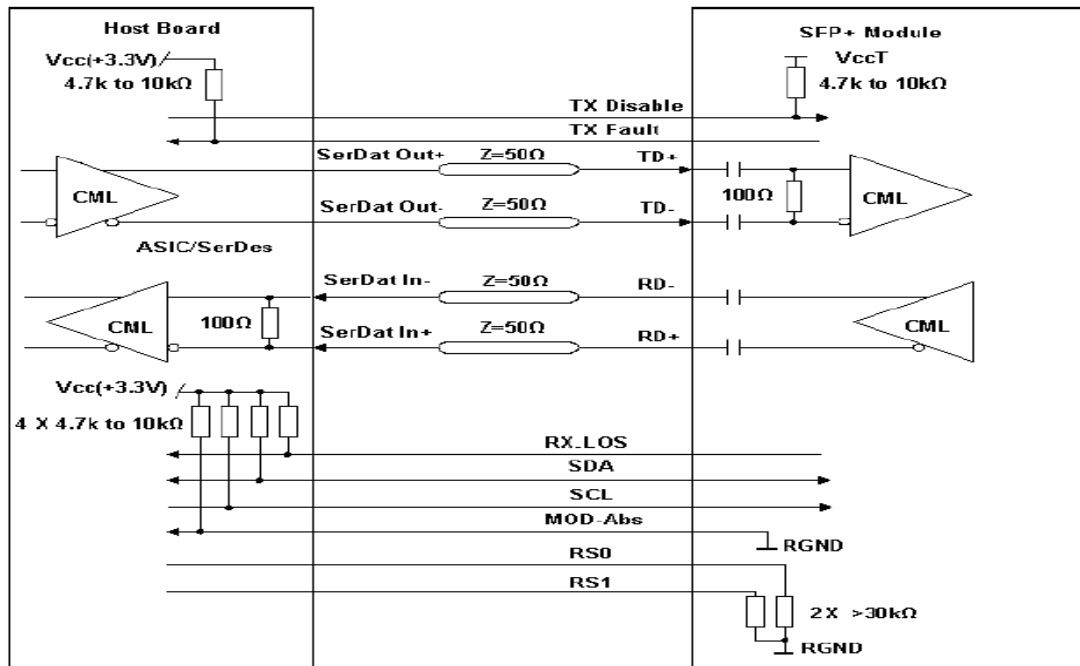

Recommended High-speed Interface Circuit

● **Mechanical Dimensions(Unit:mm)**

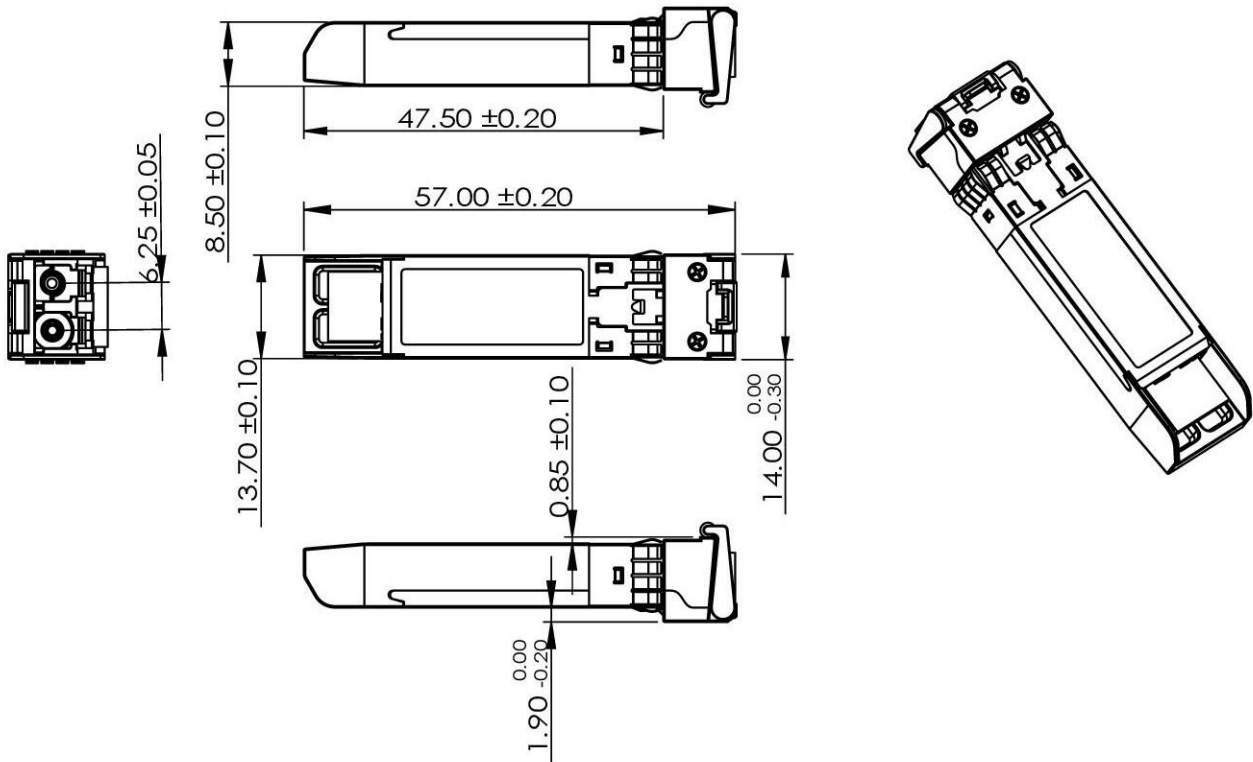

● **Document Revision**

| Version No. | Date | Reviser | Description |
|-------------|------------|---------|-----------------|
| V1.0 | 2023-11-06 | Kevin | Template update |
| | | | |
| | | | |

OPWAY reserves the right to make changes to the products or information contained herein without notice. No liability is assumed as a result of their use or application. No rights under any patent accompany the sale of any such products or information.

Published by OPWAY Communication Inc.

Copyright © OPWAY

All Rights Reserved