

10G XFP LR Optical Transceiver

PN: OP8910

Product Specification

Features:

- ✧ Support multi protocol from 9.95Gb/s to 11.3Gb/s
- ✧ Hot pluggable 30 pin connector
- ✧ Compliant with XFP MSA
- ✧ Transmission distance of 10km over Single mode fiber
- ✧ 1310nm DFB laser transmitter.
- ✧ Duplex LC connector
- ✧ 2-wire interface for management and diagnostic monitor
- ✧ Single power supply voltages : +3.3V

- ✧ Temperature range 0°C to 70°C
- ✧ Power dissipation: <1.5W
- ✧ RoHS Compliant Part

Applications:

- ✧ 10GBASE-LR/LW Ethernet
- ✧ SONET OC-192 /SDH STM-64
- ✧ 1200-SM-LL-L 10G Fibre Channel
- ✧ Other optical links

Description:

OPWAY' OP8910 Small Form Factor 10Gb/s (XFP) transceivers are compliant with the current XFP Multi-Source Agreement (MSA) Specification. The high performance uncooled 1310nm DFB transmitter and high sensitivity PIN receiver provide superior performance for Multiple applications up to 10km links.

● Absolute Maximum Ratings

Parameter	Symbol	Min	Max	Unit
Storage Temperature	T _{ST}	-40	+85	°C
Operating Temperature	T _{OP}	0	+70	°C
Supply Voltage	V _{CC}	-0.5	+4.0	V

● Electrical Characteristics

Parameter	Symbol	Min	Typ	Max	Unit	Note
Supply Voltage	V _{CC3}	3.135		3.465	V	
Supply Current	I _{CC3}			455	mA	
Module total power	P			1.5	W	
Transmitter						
Input differential impedance	R _{in}		100		Ω	1
Differential data input swing	V _{in,pp}	100		1000	mV	
Transmit Disable Voltage	V _D	2.0		V _{CC}	V	
Transmit Enable Voltage	V _{EN}	GND		GND+ 0.8	V	
Receiver						
Differential data output swing	V _{out,pp}	120		800	mV	
LOS Fault	V _{LOS fault}	V _{CC} – 0.5		V _{CCHOST}	V	2
LOS Normal	V _{LOS norm}	GND		GND+0.5	V	2

Notes

1. Connected directly to TX data input pins. AC coupling from pins into laser driver IC.
2. LOS is an open collector output. Should be pulled up with 4.7k – 10kΩ on the host board. Normal operation is logic 0; loss of signal is logic 1.

● Optical Characteristics

Parameter	Symbol	Min	Typ	Max	Unit	Ref.
Transmitter						
Operating Data Rate	BR	9.95		11.3	Gb/s	
Optical Wavelength	λ	1260	1310	1355	nm	
RMS Spectral Width	λ _{RMS}			1	nm	
Side Mode Suppression Ratio	SMSR	30			dB	
Launch Power	P _{out}	-6		0	dBm	
Average Launch power of OFF Transmitter	P _{OFF}			-30	dBm	
Optical Extinction Ratio	ER	3.5			dB	
Receiver						
Operating Data Rate	BR	9.95		11.3	Gb/s	
Optical Center Wavelength	λ _C	1260		1620	nm	
Receiver Sensitivity	Sen			-14	dBm	1
Input Saturation Power(Overload)	Sat	0			dBm	
LOS Assert	LOS _A	-30			dBm	
LOS De-Assert	LOS _D			-15	dBm	
LOS Hysteresis	LOS _H	0.5			dB	

Notes:

1. Measured with a PRBS $2^{31} - 1$ test pattern, @10.3125Gb/s, BER < 10^{-12} .

● **Pin Assignment**

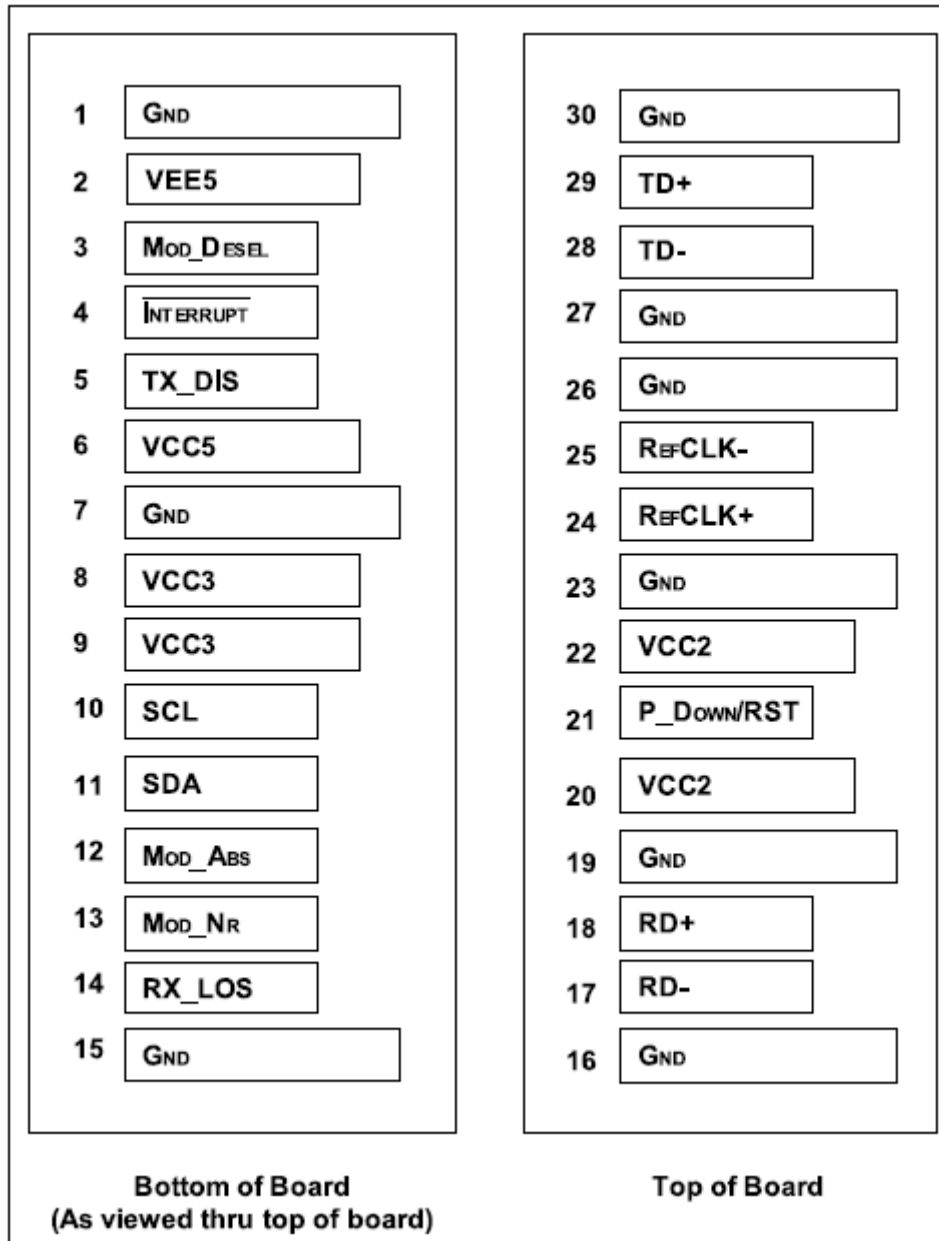

Diagram of Host Board Connector Block Pin Numbers and Names

● **Pin Description**

Pin	Logic	Symbol	Name/Description	Ref.
1		GND	Module Ground	1
2		VEE5	Optional -5.2 Power Supply – Not required	
3	LVTTL-I	Mod-Desel	Module De-select; When held low allows the module to respond to 2-wire serial interface	
4	LVTTL-O	Interrupt	Interrupt (bar); Indicates presence of an important condition which can be read over the serial 2-wire interface	2
5	LVTTL-I	TX_DIS	Transmitter Disable; Turns off transmitter laser output	
6		VCC5	+5 Power Supply	
7		GND	Module Ground	1

8		VCC3	+3.3V Power Supply	
9		VCC3	+3.3V Power Supply	
10	LVTTL- I/O	SCL	2-Wire Serial Interface Clock	2
11	LVTTL- I/O	SDA	2-Wire Serial Interface Data Line	2
12	LVTTL-O	Mod_Abs	Indicates Module is not present. Grounded in the Module	2
13	LVTTL-O	Mod_NR	Module Not Ready; Indicating Module Operational Fault	2
14	LVTTL-O	RX_LOS	Receiver Loss of Signal indicator	2
15		GND	Module Ground	1
16		GND	Module Ground	1
17	CML-O	RD-	Receiver inverted data output	
18	CML-O	RD+	Receiver non-inverted data output	
19		GND	Module Ground	1
20		VCC2	+1.8V Power Supply – Not required	
21	LVTTL-I	P_Down/RST	Power down; When high, requires the module to limit power consumption to 1.5W or below. 2-Wire serial interface must be functional in the low power mode.	
			Reset; The falling edge initiates a complete reset of the module including the 2-wire serial interface, equivalent to a power cycle.	
22		VCC2	+1.8V Power Supply – Not required	
23		GND	Module Ground	1
24	PECL-I	RefCLK+	Reference Clock non-inverted input, AC coupled on the host board – Not required	3
25	PECL-I	RefCLK-	Reference Clock inverted input, AC coupled on the host board – Not required	3
26		GND	Module Ground	1
27		GND	Module Ground	1
28	CML-I	TD-	Transmitter inverted data input	
29	CML-I	TD+	Transmitter non-inverted data input	
30		GND	Module Ground	1

Note

1. Module circuit ground is isolated from module chassis ground within the module.
2. Open collector; should be pulled up with 4.7k – 10k ohms on host board to a voltage between 3.15V and 3.6V.
3. A Reference Clock input is not required .

● **Digital Diagnostic Functions**

As defined by the XFP MSA, OPWAY’s XFP transceivers provide digital diagnostic functions via a 2-wire serial interface, which allows real-time access to the following operating parameters:

- ✓ Transceiver temperature
- ✓ Laser bias current
- ✓ Transmitted optical power
- ✓ Received optical power
- ✓ Transceiver supply voltage

It also provides a sophisticated system of alarm and warning flags, which may be used to alert end-users when particular operating parameters are outside of a factory-set normal range.

The operating and diagnostics information is monitored and reported by a Digital Diagnostics Transceiver Controller (DDTC) inside the transceiver, which is accessed through the 2-wire serial interface. When the serial protocol is activated, the serial clock signal (SCL pin) is generated by the host. The positive edge clocks data into the XFP transceiver into those segments of its memory map

that are not write-protected. The negative edge clocks data from the XFP transceiver. The serial data signal (SDA pin) is bi-directional for serial data transfer. The host uses SDA in conjunction with SCL to mark the start and end of serial protocol activation. The memories are organized as a series of 8-bit data words that can be addressed individually or sequentially. The 2-wire serial interface provides sequential or random access to the 8 bit parameters, addressed from 000h to the maximum address of the memory.

For more detailed information including memory map definitions, please see the XFP MSA Specification.

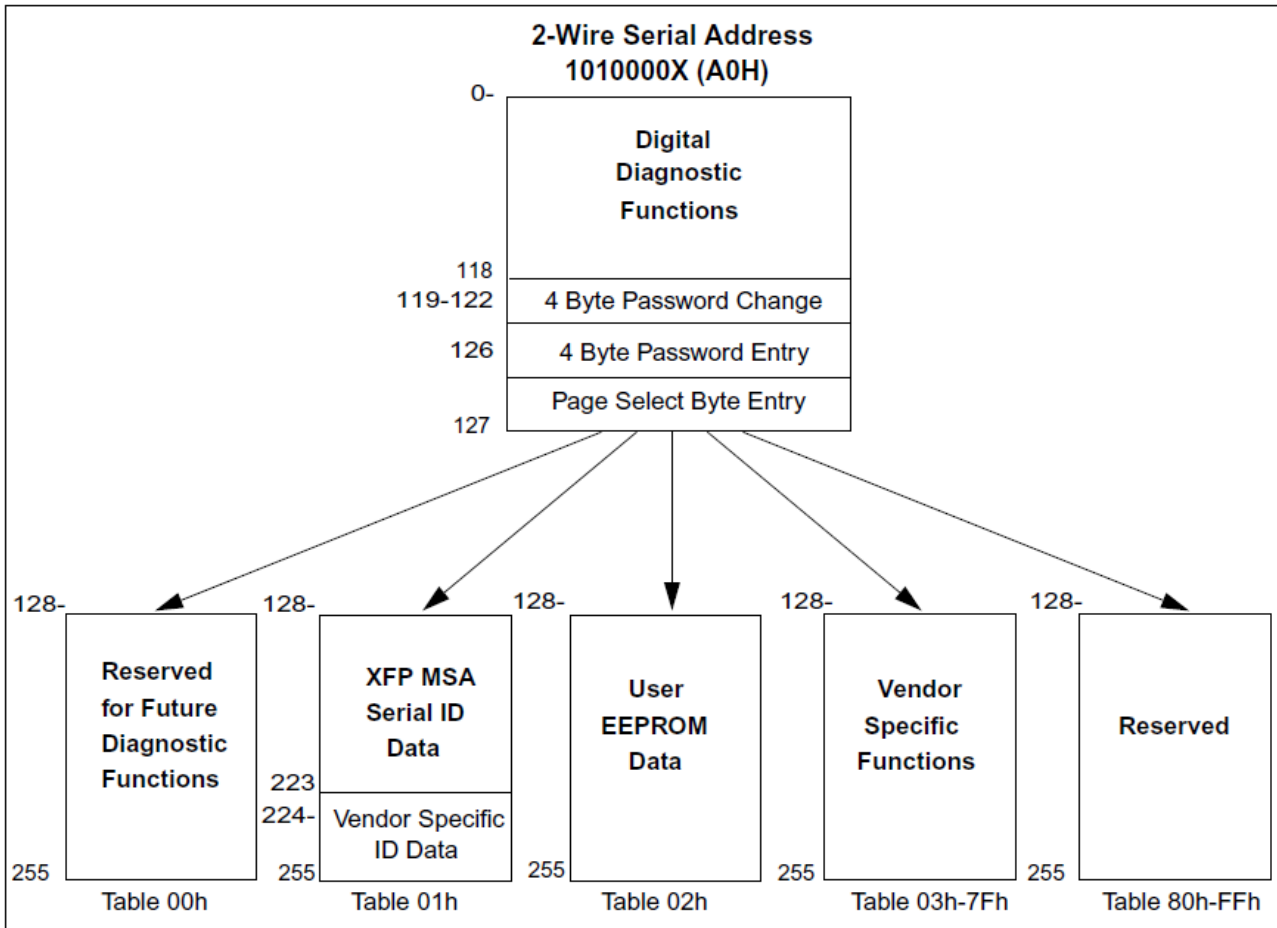

● **Recommended Circuit**

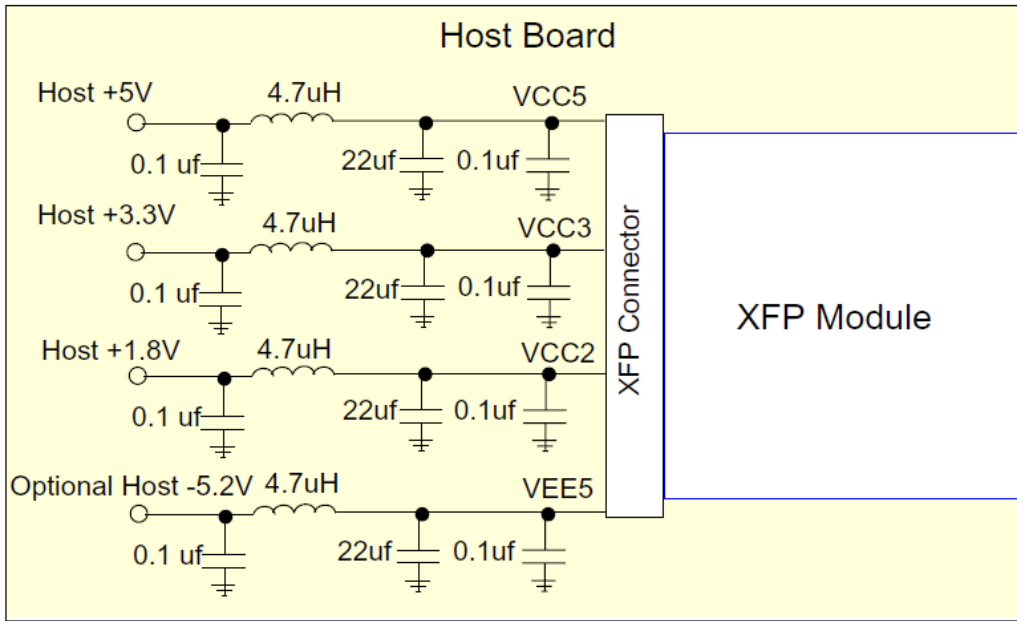

Recommended Host Board Power Supply Circuit

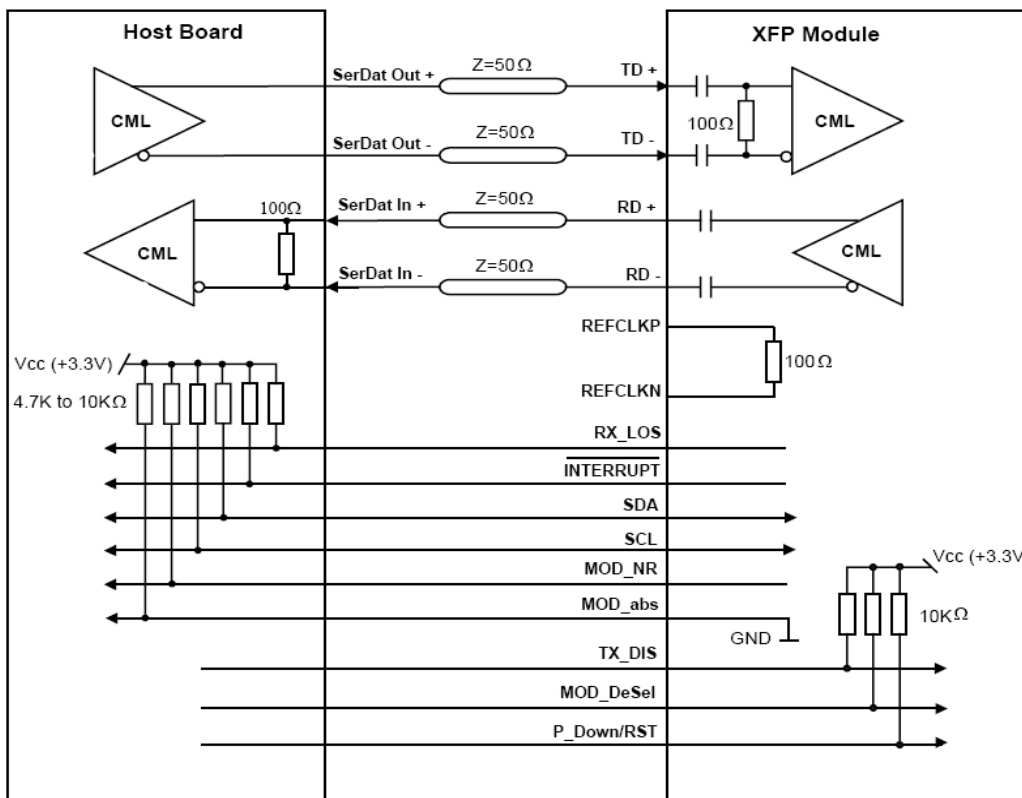

Recommended High-speed Interface Circuit

● **Mechanical Dimensions**

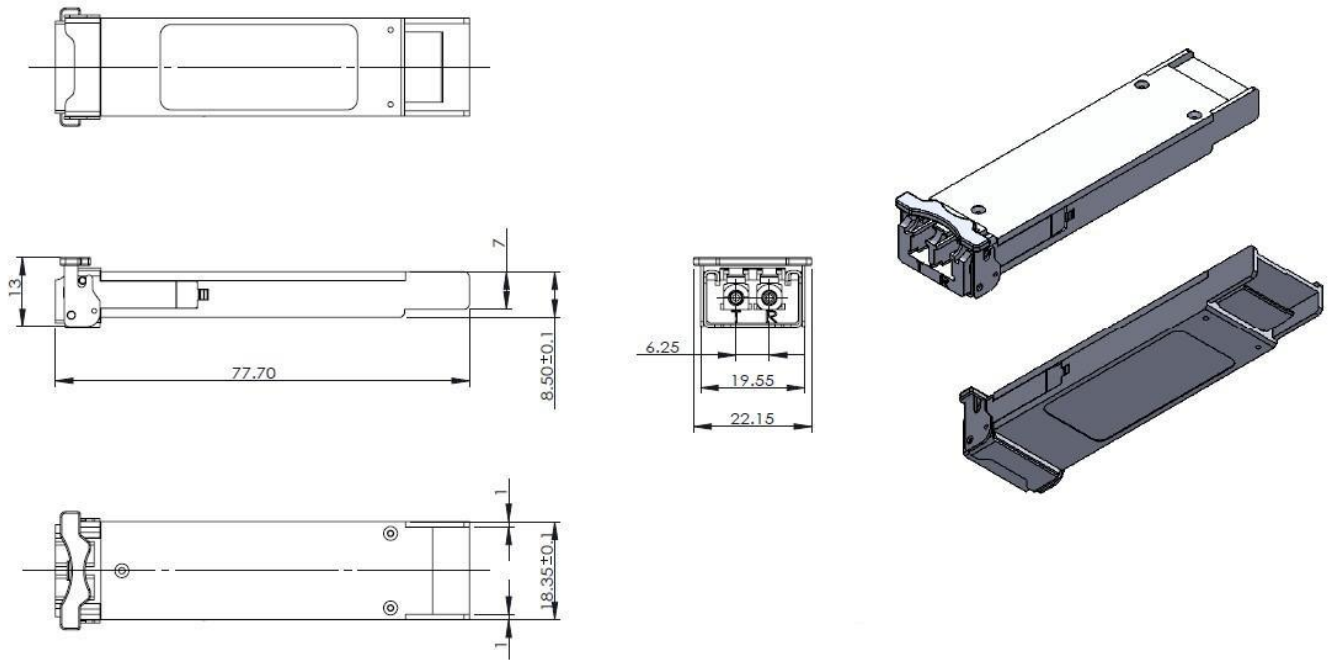

● **Document Revision**

Version No.	Date	Reviser	Description
V1.0	2023-11-16	Kevin	Template update

OPWAY reserves the right to make changes to the products or information contained herein without notice. No liability is assumed as a result of their use or application. No rights under any patent accompany the sale of any such products or information.

Published by OPWAY Communication Inc.

Copyright © OPWAY

All Rights Reserved